



The Way

Corporation

P.O. Box 12 Fowlerville, MI 48836

Phone: (517) 223-7700 Fax: (517) 223-7722

Disclaimer

THESE DRAWINGS ARE ASSEMBLED AS A GENERIC SET TO BE USED FOR THE OBSERVATION OF LAYOUT AND CONTENT ONLY. THEY WILL VARY DEPENDING ON CONTROL OPTIONS AND MACHINE CONFIGURATIONS. THEY ARE NOT INTENDED TO BE USED BY PERSONS UNFAMILIAR WITH THE SYSTEMS FOR WHICH THEY ARE DESIGNED. THE WAY CORPORATION WILL NOT BE HELD RESPONSIBLE FOR DAMAGES OR INJURY CAUSED BY THEIR IMPROPER USE.

840D sl CNC CONTROLLER SYSTEM ELECTRICAL DRAWING PACKAGE

<i>DRAWING INDEX</i>	
<i>DWG</i>	<i>PAGE TITLE</i>
D0	COVER SHEET DRAWING INDEX
D1	480VAC POWER DISTRIBUTION, 120 VAC & 24 VDC POWER SUPPLY
D2	CONTROL WIRING (24 VDC START-UP CIRCUIT)
D3	E-STOP
D4	840D sl CABLE CONNECTION & LAYOUT
D5	NCU
D6	SMART LINE MODULE
D7	X & Y AXIS SERVO DRIVE
D8	Z & A AXIS SERVO DRIVE
D9	B AXIS SERVO DRIVE
10	S7-300 I/O MODULE LAYOUT
11	S7-300 GROUP 1 MODULES 1, 2 & 3
12	S7-300 GROUP 1 MODULE 4
13	BLANK SHEET
14	OPERATORS CONTROL PANEL POWER & CONNECTION
15	MINI HANDHELD UNIT & HANDWHEEL WIRING
16	GROUNDING SYSTEM
17	BLANK SHEET
18	MAIN ENCLOSURE FABRICATION
18	MAIN ENCLOSURE LAYOUT
20	STOCKLIST



The Way
corporation

DRAWING INDEX

DATE	12/2006	SCALE	N/A	JOB NO.	MASTER
DRAWN BY	WAY CORP.	SHEET	1	OF	30

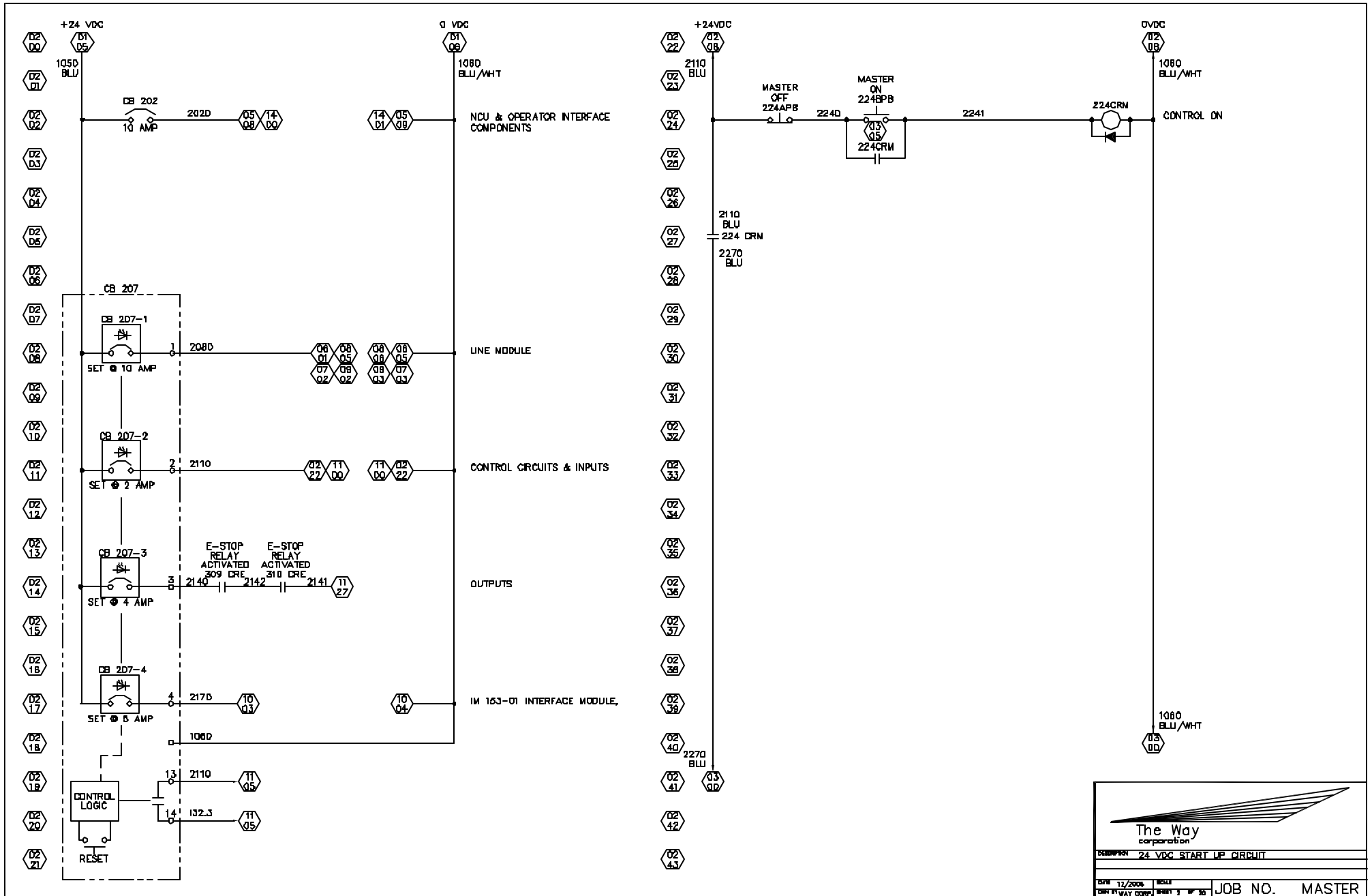

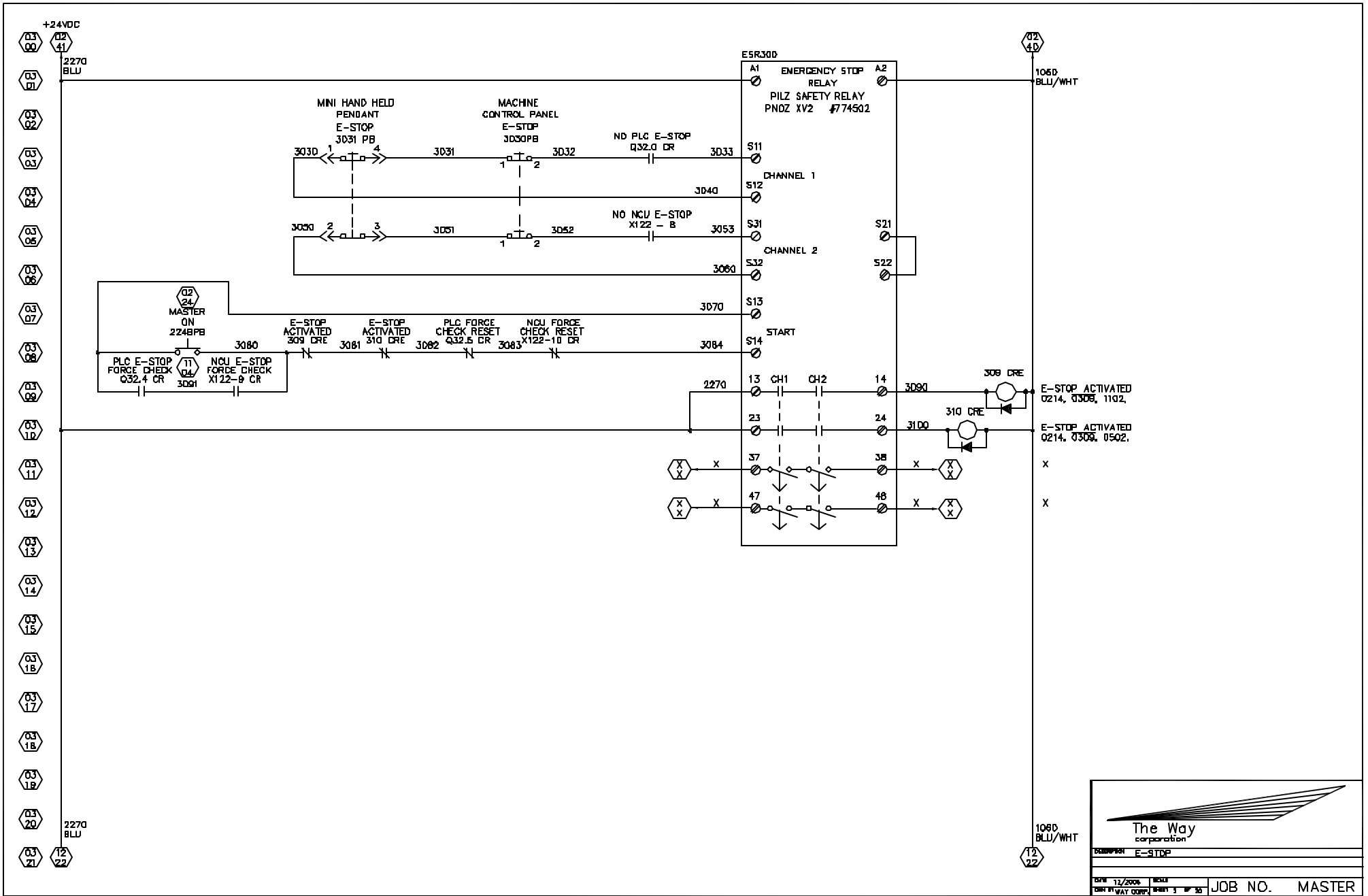

SIEMENS 840Dsl CNC OVERALL LAYOUT

- 04 00
- 04 01
- 04 02
- 04 03
- 04 04
- 04 05
- 04 06
- 04 07
- 04 08
- 04 09
- 04 10
- 04 11
- 04 12
- 04 13
- 04 14
- 04 15
- 04 16
- 04 17
- 04 18
- 04 19
- 04 20
- 04 21

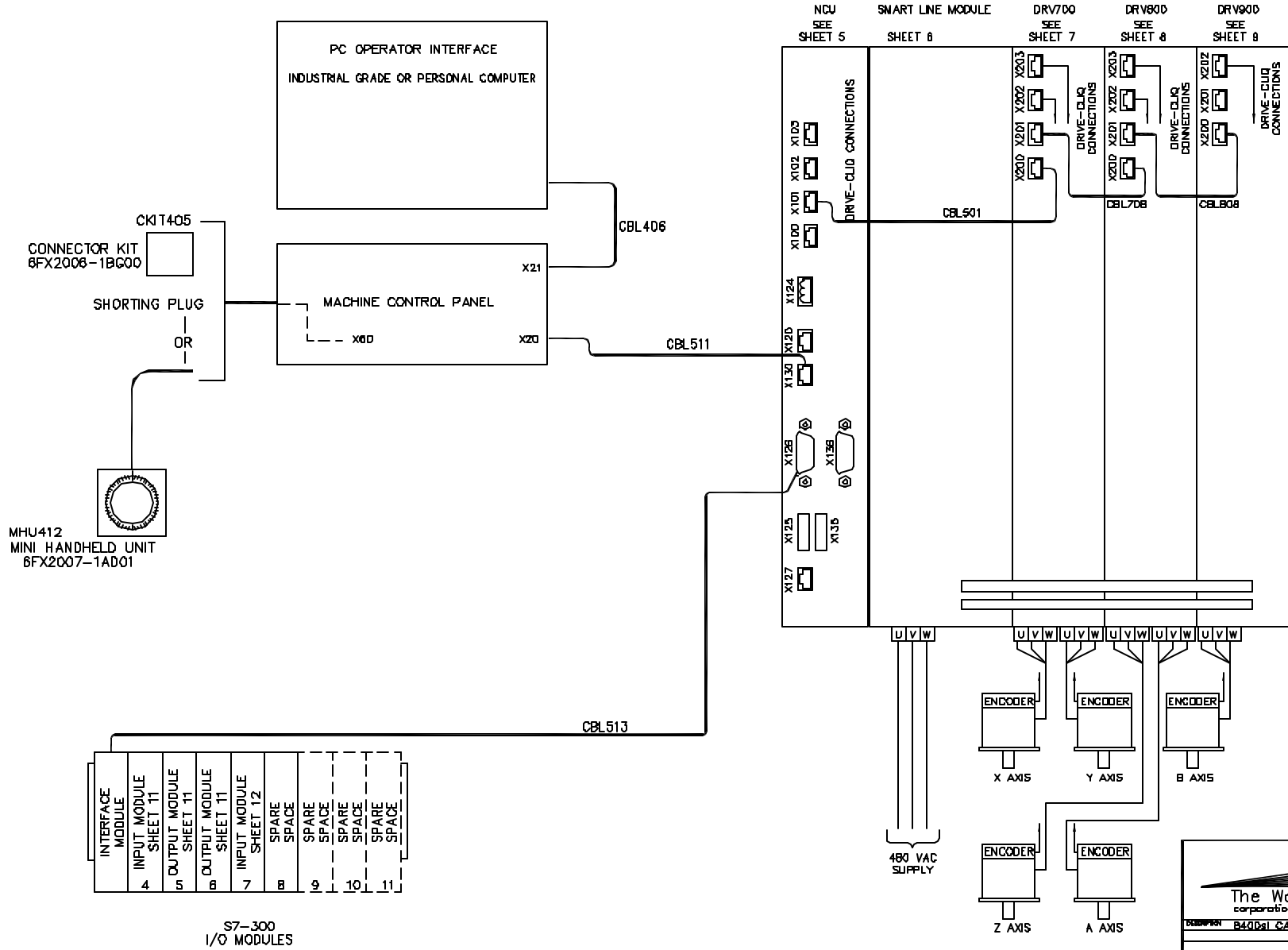

The Way
 Corporation
 840Dsl CABLE CONNECTION & DRIVE LAYOUT
 DATE: 11/2006 REVISION: JOB NO. MASTER
 SHEET 4 OF 30

SMART LINE MODULE

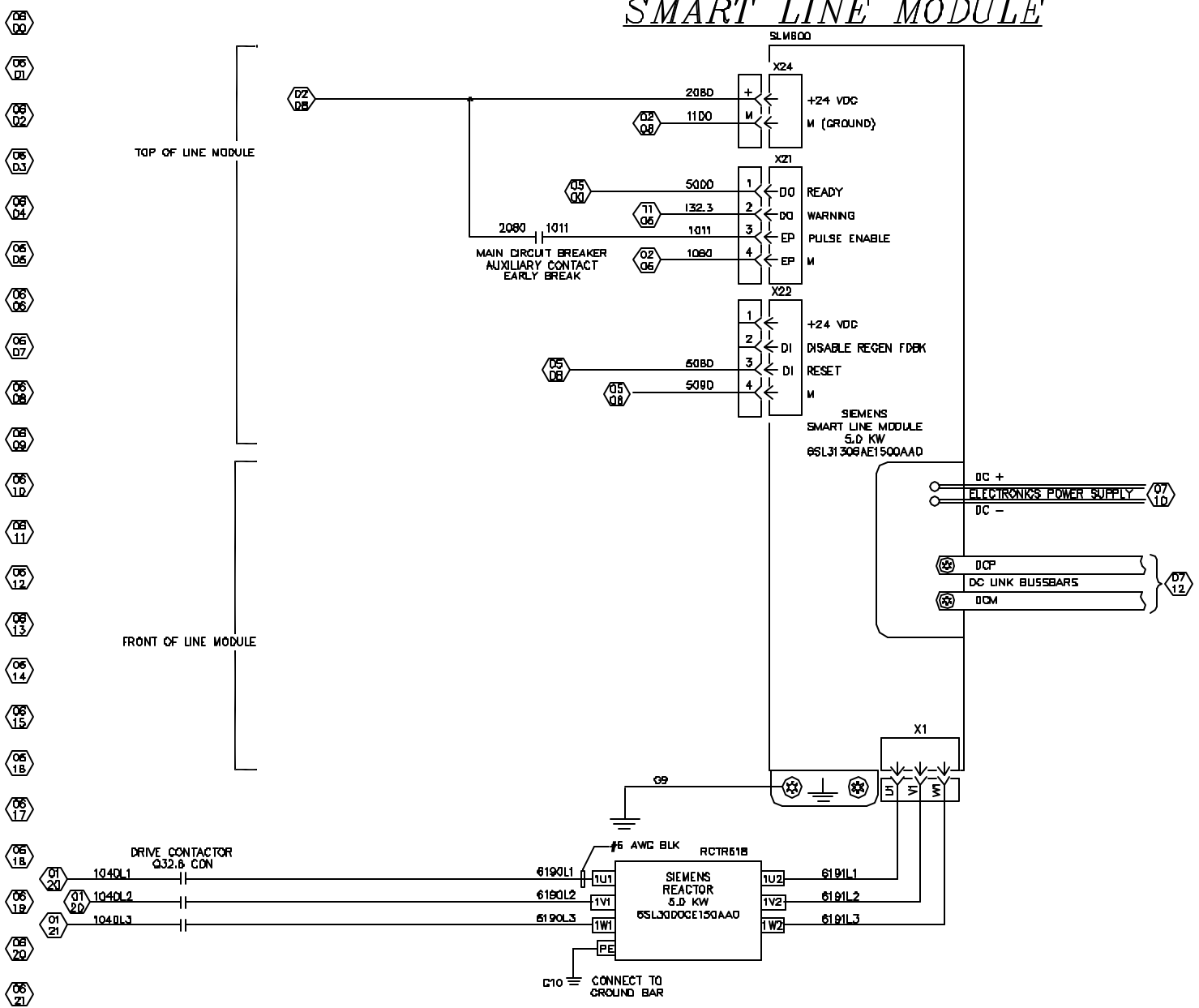

The Way
 corporation
 6000 W. 11th Street, Suite 100, Overland Park, KS 66204
 TEL: 913.241.1100 FAX: 913.241.1101

SMART LINE MODULE

DATE: 12/2006 SCALE: JOB NO. MASTER
 DESIGNED BY: DRAWN BY: SHEET 1 OF 30

Z & A AXIS SERVO DRIVE

- 08 00
- 08 01
- 08 02
- 08 03
- 08 04
- 08 05
- 08 06
- 08 07
- 08 08
- 08 09
- 08 10
- 08 11
- 08 12
- 08 13
- 08 14
- 08 15
- 08 16
- 08 17
- 08 18
- 08 19
- 08 20
- 08 21

TOP OF DRIVE MODULE

FRONT OF DRIVE MODULE

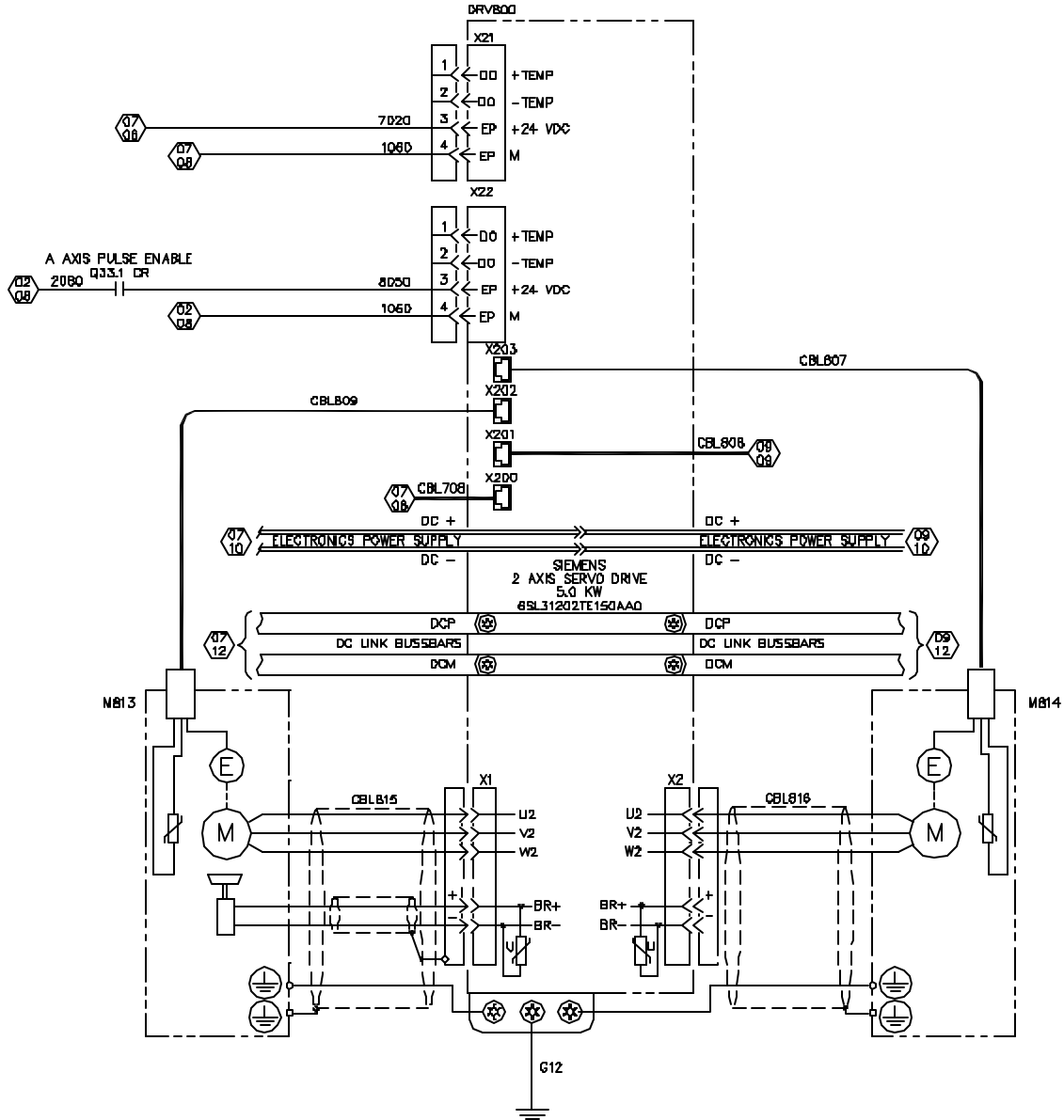

The Way
 corporation
 0808P04 Z & A AXIS DRIVE

DATE 12/2006	SCALE	JOB NO. MASTER
DRAWN BY WAY CORP.	SHEET 1 OF 30	

B AXIS SERVO DRIVE

- 08 00
- 08 01
- 08 02
- 08 03
- 08 04
- 08 05
- 08 06
- 08 07
- 08 08
- 08 09
- 08 10
- 08 11
- 08 12
- 08 13
- 08 14
- 08 15
- 08 16
- 08 17
- 08 18
- 08 19
- 08 20
- 08 21

TOP OF DRIVE MODULE

FRONT OF DRIVE MODULE

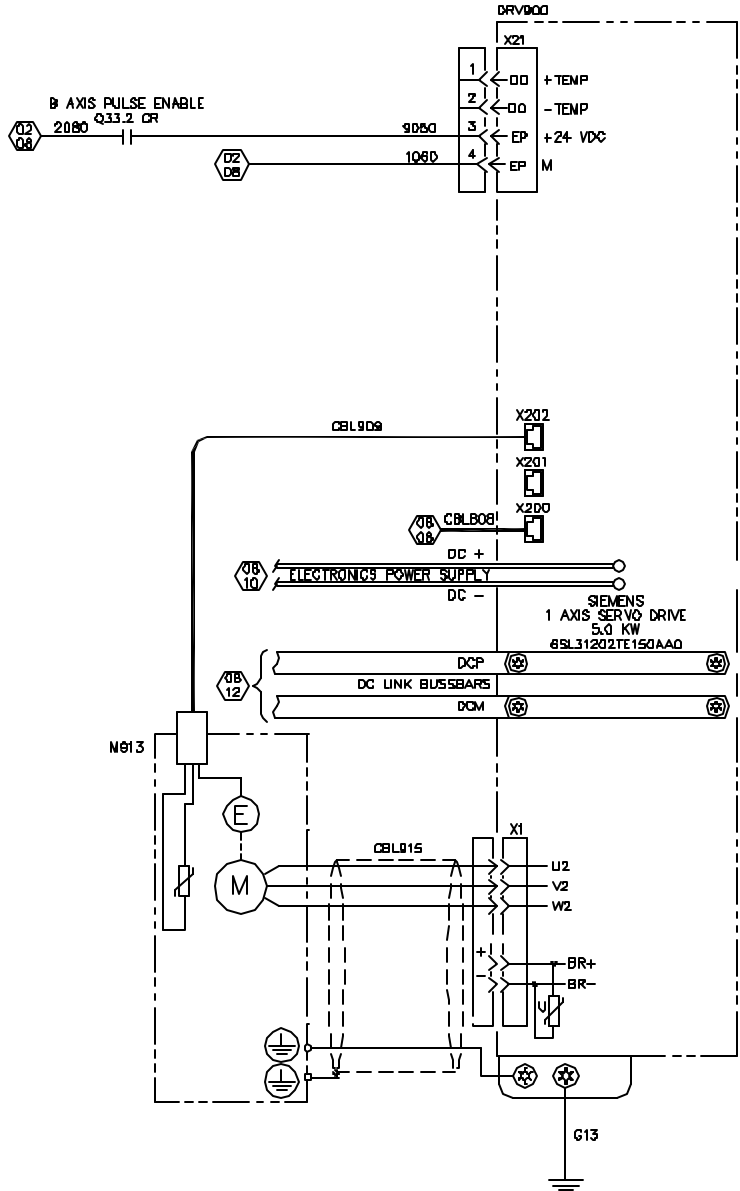



The Way
 corporation
 B AXIS DRIVE

DATE: 12/2006	REVISION: 1	JOB NO. MASTER
DRAWN BY: [unintelligible]	CHECKED BY: [unintelligible]	[unintelligible]

S7-300 I/O MODULE LAYOUT

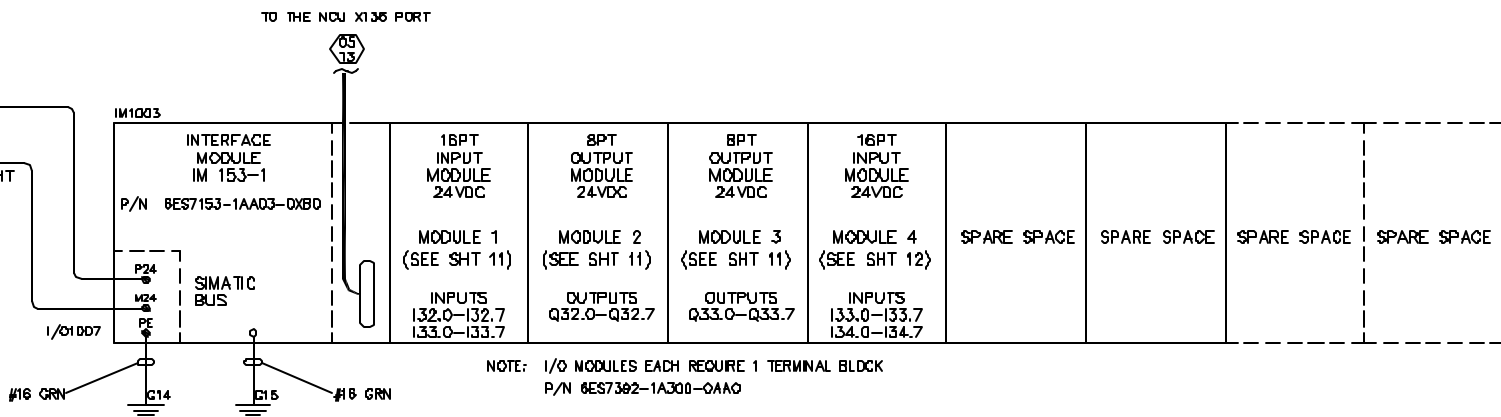
- TD 00
- TD 01
- TD 02
- TD 03
- TD 04
- TD 05
- TD 06
- TD 07
- TD 08
- TD 09
- TD 10
- TD 11
- TD 12
- TD 13
- TD 14
- TD 15
- TD 16
- TD 17
- TD 18
- TD 19
- TD 20
- TD 21



The Way
Corporation

57-300 I/O MODULE LAYOUT

DATE: 11/2006	SCALE:	JOB NO. MASTER
DRAWN BY: WAY CORP.	SHEET 16 OF 30	

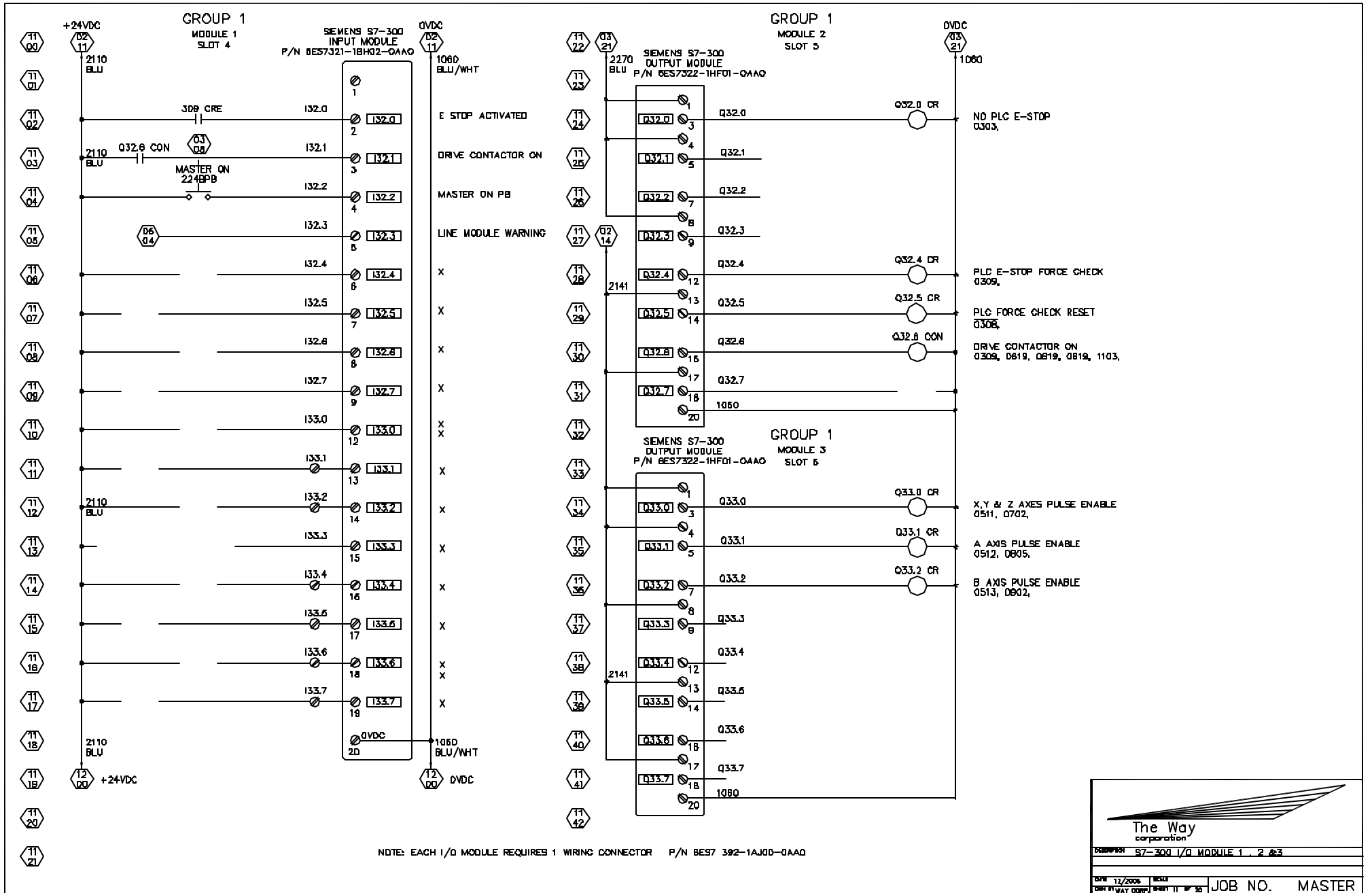

NOTE: EACH I/O MODULE REQUIRES 1 WIRING CONNECTOR P/N BES7 392-1AJ00-QAA0

The Way
 corporation

800WPHN 57-300 I/O MODULE 1, 2 & 3

DATE 12/2006	SCALE	JOB NO. MASTER
DRAWN BY WAY CORP.	SHEET 11 OF 30	

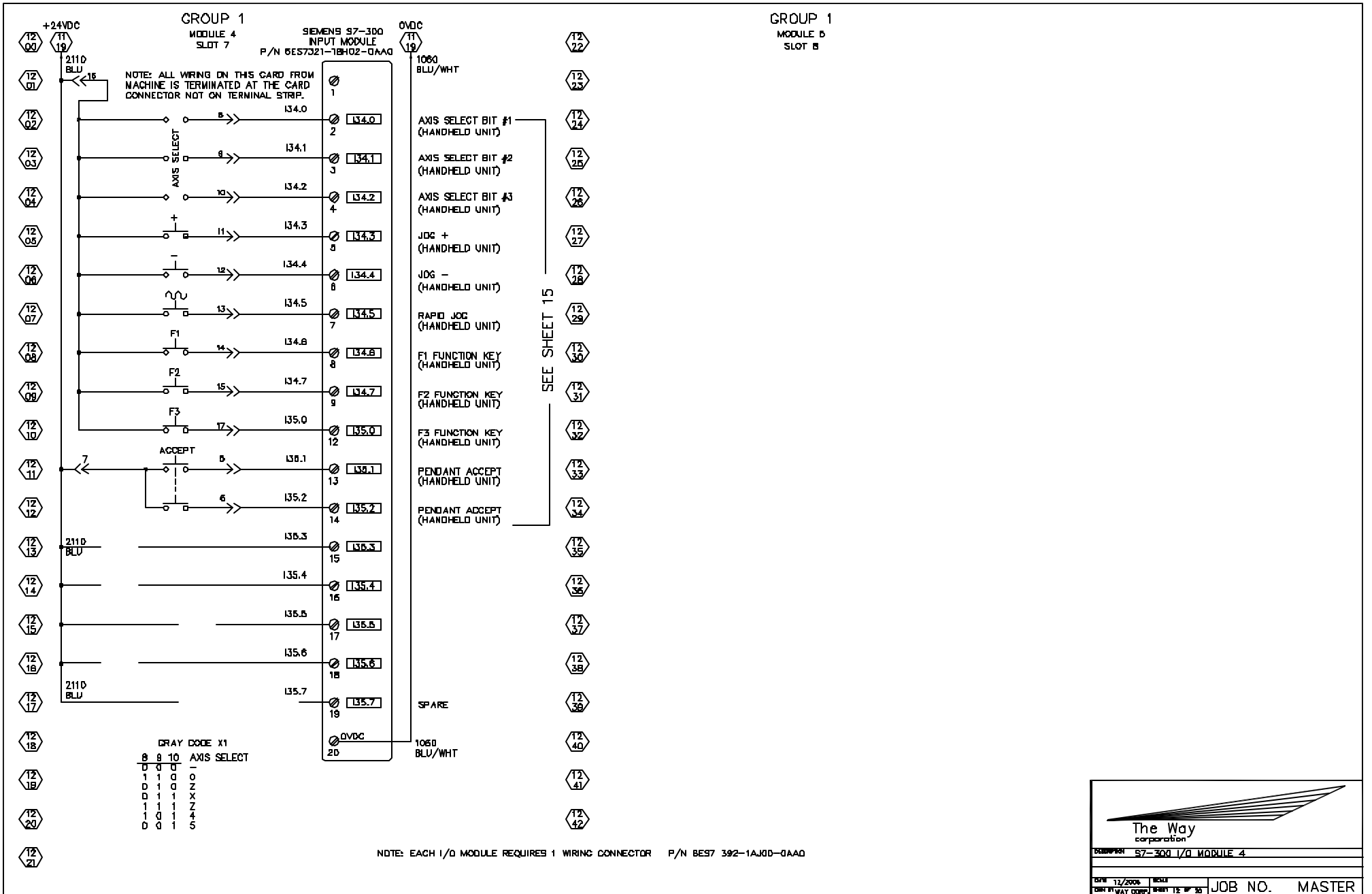

The Way
corporation

6ES7321-1BH02-0AA0 37-300 I/O MODULE 4

DATE: 12/2006	SCALE:	JOB NO. MASTER
DRAWN BY: WAY CORP.	SHEET 12 OF 30	

13
00

13
01

13
02

13
03

13
04

13
05

13
06

13
07

13
08

13
09

13
10

13
11

13
12

13
13

13
14

13
15

13
16

13
17

13
18

13
18

13
20

13
21

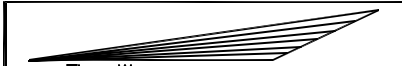

The Way
corporation

BLANK SHEET

DATE	12/2006	SCALE		JOB NO.	MASTER
FOR THE WAY CORP.		SHEET	13 OF 30		

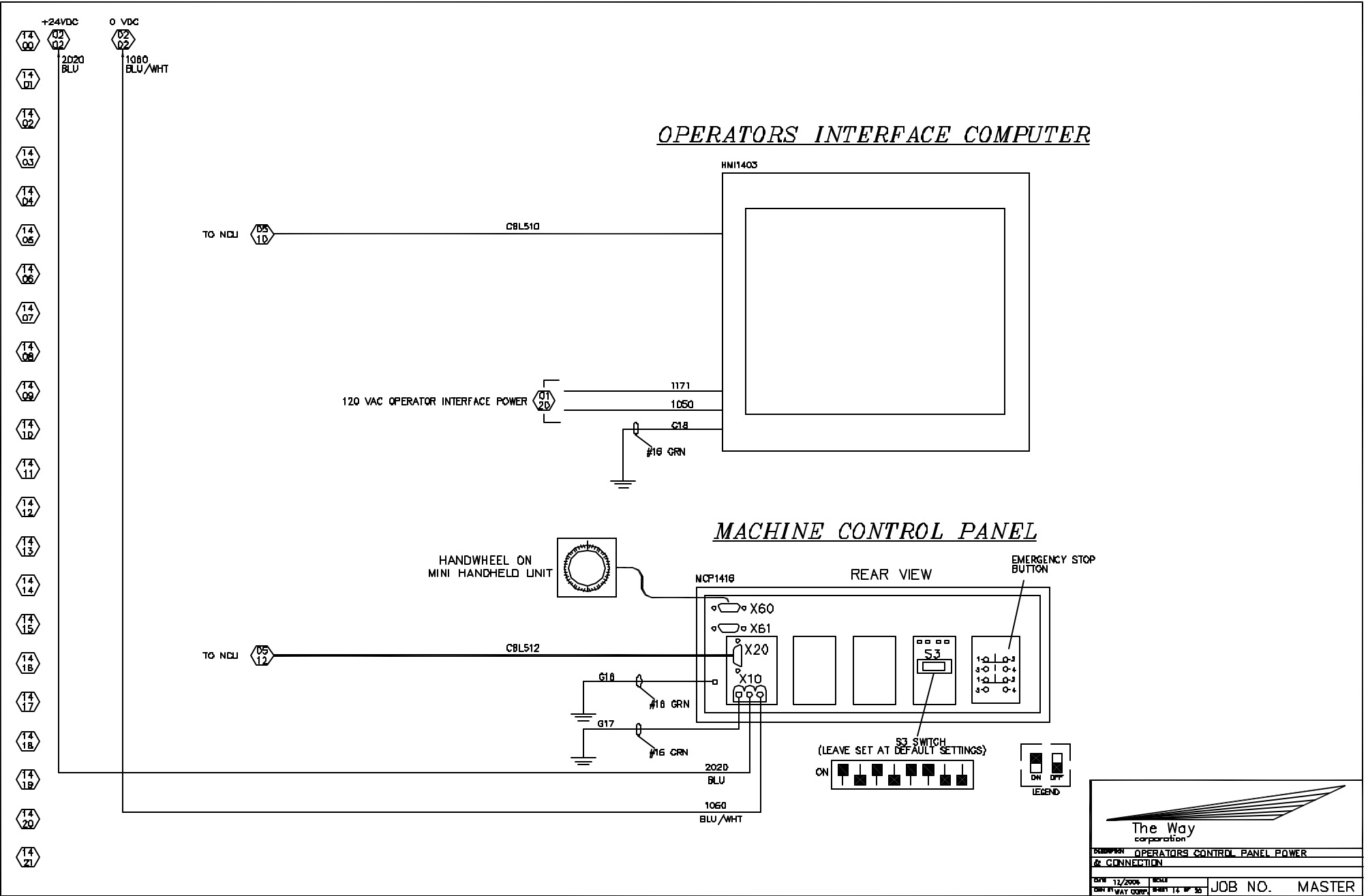

The Way
corporation

OPERATORS CONTROL PANEL POWER & CONNECTION

DATE 12/2006	REVISION	JOB NO. MASTER
DESIGNER WAY CORP.	DRAWN 12/06/06	

- 15 00
- 15 01
- 15 02
- 15 03
- 15 04
- 15 05
- 15 06
- 15 07
- 15 08
- 15 09
- 15 10
- 15 11
- 15 12
- 15 13
- 15 14
- 15 15
- 15 16
- 15 17
- 15 18
- 15 19
- 15 20
- 15 21

TO X60
PORT ON
MCP483

15 PIN FEMALE D-SUB CONNECTOR

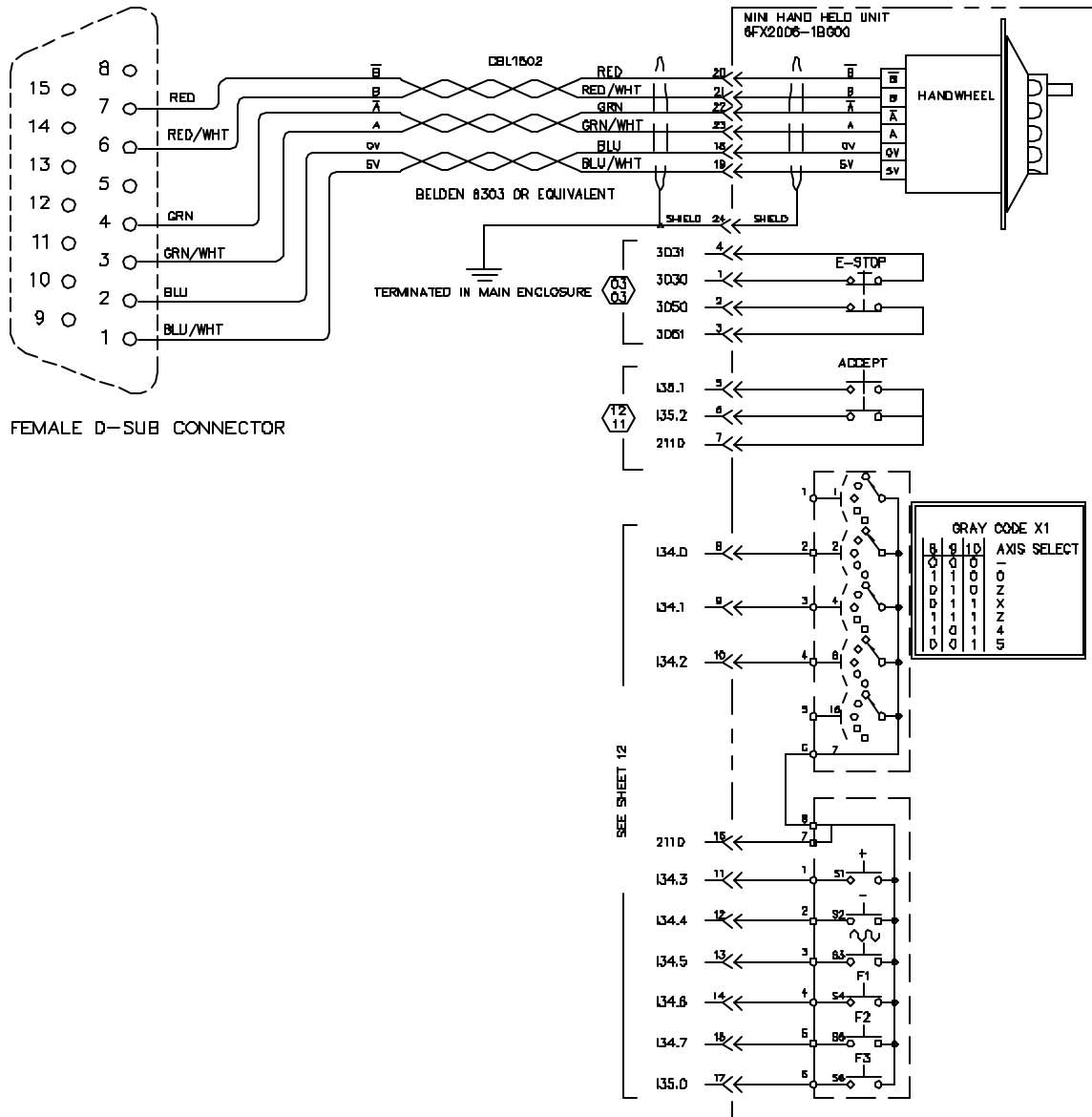

SEE SHEET 12

The Way
corporation

6FX2006-1B000 MINI HAND HELD UNIT & HAND WHEEL

DATE: 12/2006 SCALE: JOB NO. MASTER
 DRAWN BY: WAY CORP. SHEET 15 OF 30

GROUNDING LAYOUT

MAIN ELECTRICAL PANEL

FROM PLANT
POWER DROP
AND GROUND ROD.

- TE 00
- TE 01
- TE 02
- TE 03
- TE 04
- TE 05
- TE 06
- TE 07
- TE 08
- TE 09
- TE 10
- TE 11
- TE 12
- TE 13
- TE 14
- TE 15
- TE 16
- TE 17
- TE 18
- TE 19
- TE 20
- TE 21

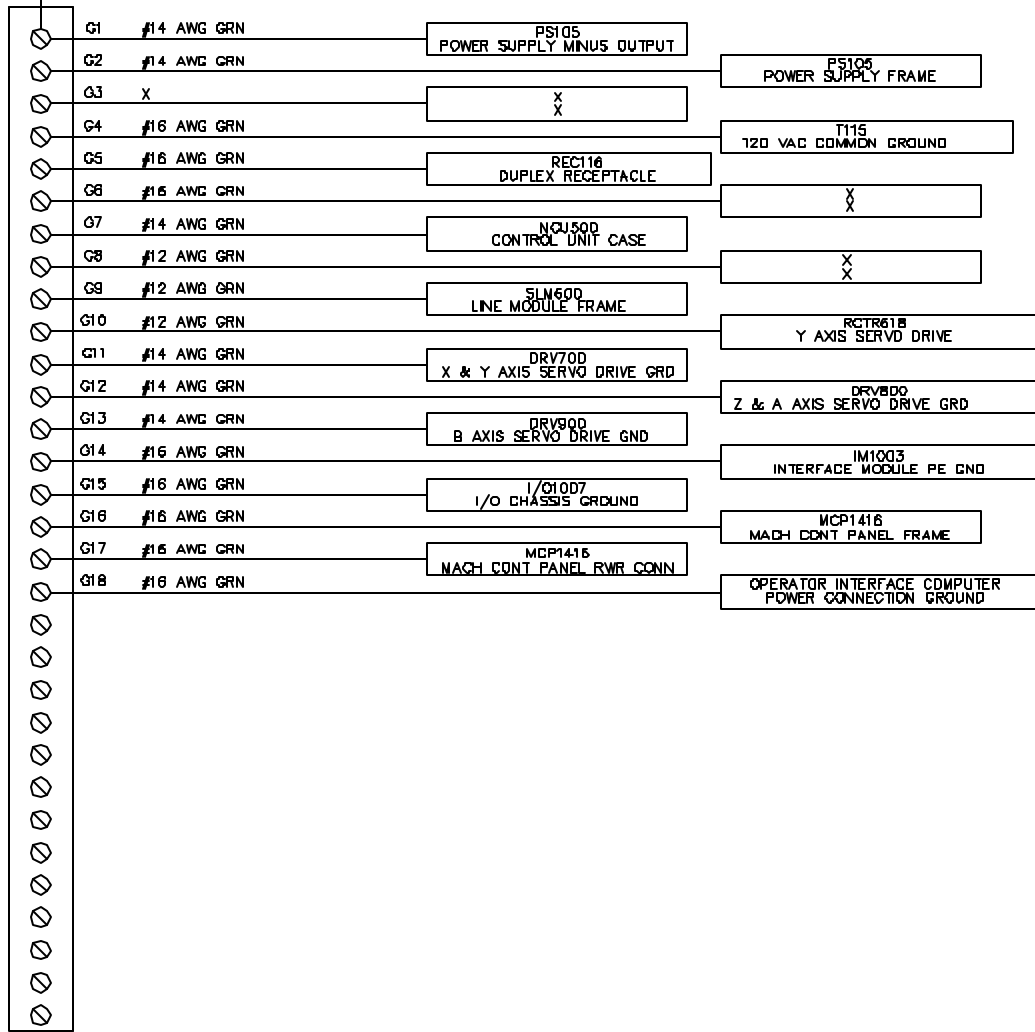

GROUNDING NOTE:

TO ELIMINATE THE POSSIBILITIES OF ELECTRICAL NOISE AFFECTING THE OPERATION OF THE COMPUTERIZED NUMERICAL CONTROL SYSTEM SUPPLIED, IT IS RECOMMENDED THAT A TRUE UNINTERRUPTABLE EARTH GROUND BE PROVIDED (i.e. A COPPER OR COPPER CLAD GROUND ROD DRIVEN AT LEAST EIGHT FEET INTO THE EARTH AND CONNECTED TO THE MAIN CONTROL ENCLOSURE WITH A #8 OR LARGER COPPER STRAP OR WIRE THE LENGTH OF WHICH SHOULD BE AS SHORT AS POSSIBLE AND ATTACHED AT EACH END WITH GOOD MECHANICAL BONDS). IT IS SUGGESTED THAT THE MECHANICAL BONDS BE SEALED (RTV SILICONE) TO RETARD CHEMICAL OXIDATION.



The Way
corporation

GROUND WIRING

DATE 11/2006	REVISION
DRN BY WAY CORP	DRWT 16 OF 20

JOB NO. MASTER

17
00

17
01

17
02

17
03

17
04

17
05

17
06

17
07

17
08

17
09

17
10

17
11

17
12

17
13

17
14

17
15

17
16

17
17

17
18

17
19

17
20

17
21

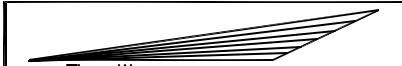

The Way
corporation

BLANK SHEET

DATE: 12/2006 SHEET: 17 OF 30 JOB NO. MASTER

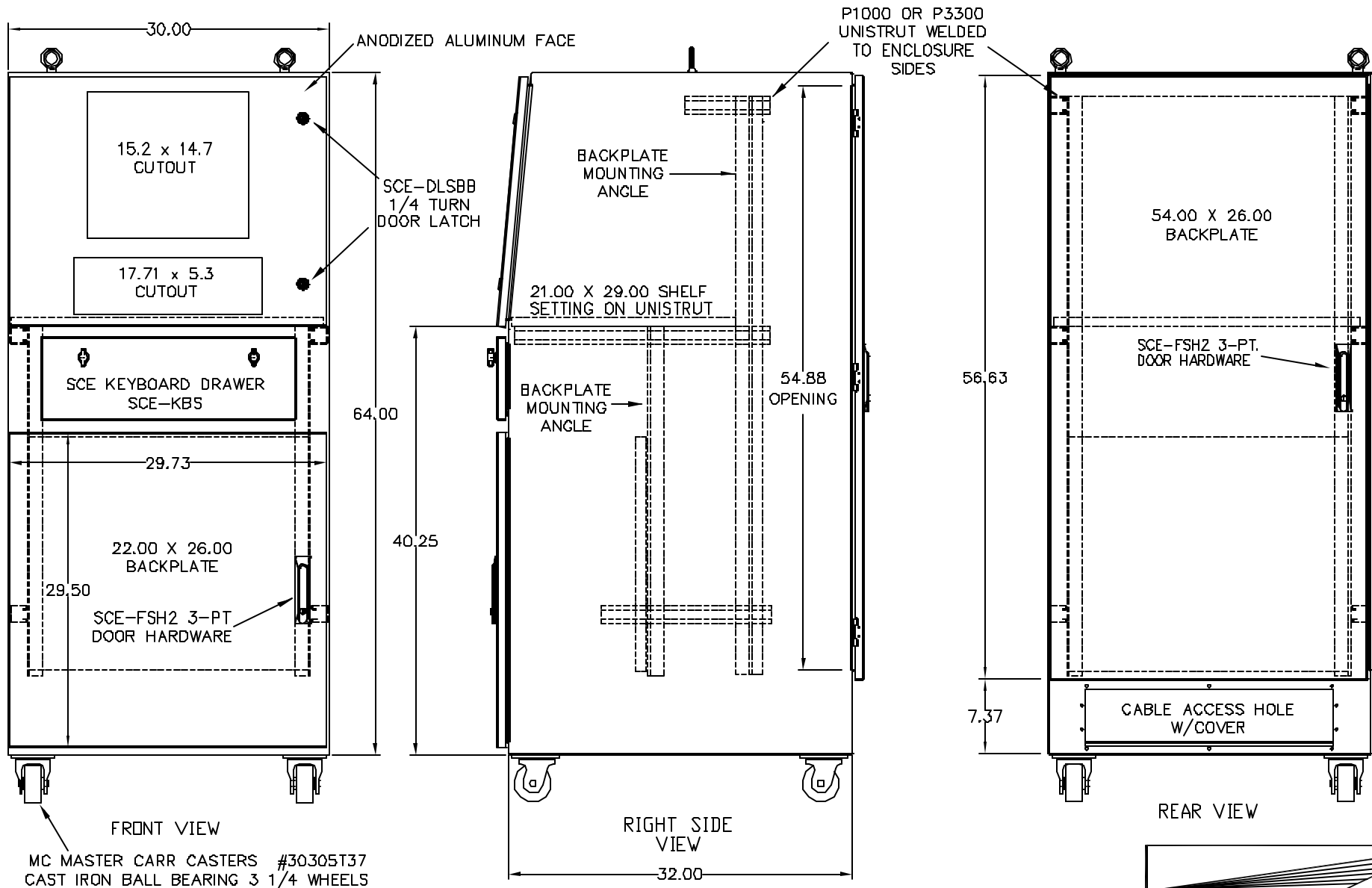

The Way
corporation

OPERATOR STATION & CONTROL ENCLOSURE

DATE 1/28/77	SCALE	JOB NO.
DRN BY WAY CORP	DRWT BY WAY CORP	

DIAGRAM ID	QTY	MANUFACTURE	PRODUCT	CATALOG NO.	DIAGRAM ID	QTY	MANUFACTURE	PRODUCT	CATALOG NO.
ENCLOSURE	1	FABRICATED BY VENDOR	MAIN ELECTRICAL ENCLOSURE W/BACKPLATE		CBL909	1	SIEMENS	5 METER SIGNAL CABLE	6FX8002-2DC10-1AF0
CB101	1	SQUARE D	600 VOLT 3 PHASE 30 AMP CIRCUIT BREAKER	CLASS 9421 FAL36030	CBL915	1	SIEMENS	5 METER POWER CABLE	6FX8002-5CS01-1AF0
CB101	1	SQUARE D	CIRCUIT BREAKER OPERATOR 3" HANDLE	CLASS 9421 LH3	M913	1	SIEMENS	SERVO MOTOR 1.10 KW, 3.5 NM, 4 AMP, 3000 RPM, W/BRAKE	1FK7044-7AF71-1FB0
CB101	1	SQUARE D	OPERATING MECHANISM	CLASS 9421 LF1	IM1003	1	SIEMENS	I/O INTERFACE MODULE IM153-1	6ES7153-1AA03-0XB0
CB101	1	SQUARE D	AUXILIARY SWITCH	CLASS 9999 R47	VO1007	1	SIEMENS	S7-300 I/O MOUNTING RAIL 19"	6ES7390-1AE80-0AA0
CB101	1	SQUARE D	STANDARD OPERATING SHAFT	CLASS 9421 L58	MODULE 1	1	SIEMENS	SM 116" DIGITAL INPUT, 24VDC	6ES7321-1BH02-0AA0
GB102	1	NSI	GROUND BAR	1018M	MODULE 1	1	SIEMENS	20 PIN I/O MODULE CONNECTOR	6ES7392-1AJ00-0AA0
MSP105	1	SIEMENS	2.2 - 3.2 AMP MOTOR PROTECTOR & MANUAL STARTER	3RV1021-1DA10	MODULE 2	1	SIEMENS	20 PIN I/O MODULE CONNECTOR	6ES7392-1AJ00-0AA0
PS105	1	SIEMENS	480 VOLT 3 PHASE 24VDC 40 AMP POWER SUPPLY	6EP1437-3BA00	Q32.0 CR	1	ALLEN-BRADLEY	1 POLE RELAY 24VDC COIL 10 AMP FORM C CONTACT	700-HK36Z24
T115	1	DONGAN	750 VA SINGLE PHASE 480-VAC PRI/120 VAC SEC. TRANSFORMER	50-0750-053	Q32.0 CR	1	ALLEN-BRADLEY	1 POLE RELAY SOCKET	700-HN121
CB114	1	ALTECH	4 AMP 2 POLE 600 VAC CIRCUIT BREAKER D CURVE	2DU4 (ALLIED NO. 501-2259)	Q32.4 CR	1	ALLEN-BRADLEY	1 POLE RELAY 24VDC COIL 10 AMP FORM C CONTACT	700-HK36Z24
CB116	1	ALTECH	6 AMP 1 POLE 277 VAC CIRCUIT BREAKER STD C CURVE	1CU6 (ALLIED NO. 501-2035)	Q32.4 CR	1	ALLEN-BRADLEY	1 POLE RELAY SOCKET	700-HN121
REC116	1	APPLETON	HANDY BOX	4CS-1/2	Q32.5 CR	1	ALLEN-BRADLEY	1 POLE RELAY 24VDC COIL 10 AMP FORM C CONTACT	700-HK36Z24
REC116	1	APPLETON	COVER	2510	Q32.5 CR	1	ALLEN-BRADLEY	1 POLE RELAY SOCKET	700-HN121
REC116	1	HUBBELL	DUPLEX RECEPTACLE	CR5262	Q32.6 CON	1	SIEMENS	3 POLE SIZE 0 MOTOR CON W/24 VDC COIL 35AMP/10HP @460 VOLT	3RT1025-1BB40
CB119	1	ALTECH	2.0 AMP 1 POLE 277VAC CIRCUIT BREAKER D CURVE	1DU2 (ALLIED NO. 501-2048)	Q32.6 CON	2	SIEMENS	N.O. AUXILIARY FRONT MOUNTED CONTACT BLOCK	3RH1921-1CA10
PCU120	1		STANDARD PERSONAL COMPUTER		MODULE 3	1	SIEMENS	OUTPUT MODULE 8PTS RELAY 2A	6ES7322-1HF01-0AA0
CB202	1	ALTECH	10 AMP 1 POLE 277 VAC CIRCUIT BREAKER	1CU10 (ALLIED NO. 501-2019)	MODULE 3	1	SIEMENS	20 PIN I/O MODULE CONNECTOR	6ES7392-1AJ00-0AA0
CB207	1	SIEMENS	4 CIRCUIT DIAGNOSTIC MODULE	6EP1961-2B400	Q33.0 CR	1	SIEMENS	4 POLE 4 NO 24VDC COIL W/ SUPPRESSION DIODE SCREW	3RH1140-1BB40
224APB	1	SAIA-BURGESS	ROUND MOMENTARY OPER. FASTON CONNECT	505008 (ALLIED NO. 804-6060)	Q33.1 CR	1	SIEMENS	4 POLE 4 NO 24VDC COIL W/ SUPPRESSION DIODE SCREW	3RH1140-1BB40
224APB	1	SAIA-BURGESS	RED FLAT LENS	464421 (ALLIED NO. 804-8064)	Q33.2 CR	1	SIEMENS	4 POLE 4 NO 24VDC COIL W/ SUPPRESSION DIODE SCREW	3RH1140-1BB40
224APB	1	SAIA-BURGESS	CONTACT BLOCK FASTON TYPE 1NO/1NC	593560 000 (ALLIED NO. 804-9997)	MODULE 4	1	SIEMENS	SM 116" DIGITAL INPUT, 24VDC	6ES7321-1BH02-0AA0
224BPB	1	SAIA-BURGESS	ROUND MOMENTARY OPER. FASTON CONNECT	505008 (ALLIED NO. 804-6060)	MODULE 4	1	SIEMENS	20 PIN I/O MODULE CONNECTOR	6ES7392-1AJ00-0AA0
224BPB	1	SAIA-BURGESS	GREEN FLAT LENS	464221 (ALLIED NO. 804-8062)					
224BPB	1	SAIA-BURGESS	CONTACT BLOCK FASTON TYPE 2NO/2NC	593563 000 (ALLIED NO. 804-1235)	Q32.4LT	1	SIEMENS	BLUE STEADY LIGHT LED ELEMENT	8WD44 20-5AF
224BPB	1	SAIA-BURGESS	CONTACT BLOCK FASTON TYPE 1NO/1NC	593560 000 (ALLIED NO. 804-9997)	Q32.4LT	1	SIEMENS	RED STEADY LIGHT LED ELEMENT	8WD44 20-5AB
224CRM	1	SIEMENS	4 POLE 4 NO 24VDC COIL W/ SUPPRESSION DIODE SCREW	3RH1140-1BB40	Q32.4LT	1	SIEMENS	GREEN STEADY LIGHT LED ELEMENT	8WD44 20-5AC
303CR	1	SIEMENS	SAFETY RELAY W/2 INSTANT & 2 NO TIME DELAY OFF CONTACTS	7MC2 X/2 #774502	Q32.4LT	1	SIEMENS	YELLOW STEADY LIGHT LED ELEMENT	8WD44 20-5AD
303CR	1	SIEMENS	4 POLE 3 NO 1 NC 24VDC COIL W/ SUPPRESSION DIODE SCREW	3RH1131-1BB40	Q32LT	1	SIEMENS	SIGNAL COLUMN MOUNTING ELEMENT	8WD44 08-0AA
310CR	1	SIEMENS	4 POLE 3 NO 1 NC 24VDC COIL W/ SUPPRESSION DIODE SCREW	3RH1131-1BB40	Q32LT	1	SIEMENS	SIGNAL COLUMN CAST SINGLE FOOT	8WD43 08-0DC
CKT405	1	SIEMENS	CONNECTOR KIT & SHORTING PLUG FOR MINI HANDHELD UNIT	6FX2006-1B000	Q32LT	1	SIEMENS	SIGNAL COLUMN 400 MM TUBE	8WD43 08-0EB
MHJ4112	1	SIEMENS	MINI HANDHELD UNIT	6FX2007-1AD01					
CBL510	2	AMP	RJ45 CAT 5 CONNECTOR	5-558530-3 (ALLIED NO. 512-5731)	HMI1403	1		STANDARD PERSONAL COMPUTER MONITOR	
CBL510	2	AMP	RJ45 CAT 5 CONNECTOR BLACK CABLE BOOT	569875-1 (ALLIED NO. 512-5860)	MCP1416	1	SIEMENS	MACHINE CONTROL PANEL MCP483CIE, 19" WIDE, MECH. KEYS	6FC5303-0AF22-0AA0
CBL511	2	AMP	RJ45 CAT 5 CONNECTOR	5-558530-3 (ALLIED NO. 512-5731)	MCP1416	1	SIEMENS	KEY CAPS	6FC5248-0AF21-0AA0
CBL511	2	AMP	RJ45 CAT 5 CONNECTOR BLACK CABLE BOOT	569875-1 (ALLIED NO. 512-5860)					
CBL513	1	SIEMENS	PROFIBUS CONNECTOR 35 DEGREE W/ PG PORT	6ES7972-0BB41-0XA0					
CBL513	1	SIEMENS	PROFIBUS CONNECTOR 35 DEGREE W/O PG PORT	6ES7972-0BA41-0XA0					
CBL1502	1	AMP	15 PIN PLUG D-SUB MALE CONNECTOR	205206-1 (ALLIED NO. 512-0015)					
CBL1502	10	AMP	PIN FOR D-SUB CONNECTOR	6-68506-1 (ALLIED NO. 512-9500)					
CBL1502	1	AMP	15 PIN D-SUB CONNECTOR HOOD METAL SHIELD	748676-2 (ALLIED NO. 512-8755)					
NCU500	1	SIEMENS	SINUMERIK 840D sl:NCU710.1 WITH PLC 317-2DP	6FC5371-0AA10-0AA0					
CBL510	2	AMP	RJ45 CAT 5 CONNECTOR	5-558530-3 (ALLIED NO. 512-5731)					
CBL510	2	AMP	RJ45 CAT 5 CONNECTOR BLACK CABLE BOOT	569875-1 (ALLIED NO. 512-5860)					
X122-8CR	1	ALLEN-BRADLEY	1 POLE RELAY 24VDC COIL 10 AMP FORM C CONTACT	700-HK36Z24					
X122-8CR	1	ALLEN-BRADLEY	1 POLE RELAY SOCKET	700-HN121					
X122-9CR	1	ALLEN-BRADLEY	1 POLE RELAY 24VDC COIL 10 AMP FORM C CONTACT	700-HK36Z24					
X122-9CR	1	ALLEN-BRADLEY	1 POLE RELAY SOCKET	700-HN121					
X122-10CR	1	ALLEN-BRADLEY	1 POLE RELAY 24VDC COIL 10 AMP FORM C CONTACT	700-HK36Z24					
X122-10CR	1	ALLEN-BRADLEY	1 POLE RELAY SOCKET	700-HN121					
SLM600	1	SIEMENS	5KW SMART LINE MODULE	6SL1310-6AE15-0A00					
RCTR618	1	SIEMENS	5KW REACTOR	6LS3000-0CE15-0AA0	SOFTWARE	1	SIEMENS	EMBEDDED START-UP W/LICENSE	6FC5840-01XG0-0Y0A0
DRV700	1	SIEMENS	INTERNAL AIR COOLING 2 X 5 DOUBLE MOTOR MODULE	6SL1310-02TE15-0AA0	SOFTWARE	1	SIEMENS	CURRENT VERSION HMI ADVANCED PC/PG COPY LICENSE	6FC5253-0BX40-0AG1
CBL707	1	SIEMENS	5 METER SIGNAL CABLE	6FX8002-2DC10-1AF0	SOFTWARE	1	SIEMENS	SINUMERIK 840D sl:SINUMERIK HMI COPY LICENSE OA; SOFTWARE OPTION	6FC5800-0AP02-0YBA
CBL708	2	AMP	RJ45 CAT 5 CONNECTOR	5-558530-3 (ALLIED NO. 512-5731)	SOFTWARE	1	SIEMENS	PATH VELOCITY-DEPENDENT ANALOG-VALUE (LASER POWER CONTROL)	6FC5800-0AM37-0YB0
CBL708	2	AMP	RJ45 CAT 5 CONNECTOR BLACK CABLE BOOT	569875-1 (ALLIED NO. 512-5860)					
CBL709	1	SIEMENS	5 METER SIGNAL CABLE	6FX8002-2DC10-1AF0					
CBL715	1	SIEMENS	5 METER POWER CABLE	6FX8002-5CS01-1AF0					
CBL716	1	SIEMENS	5 METER POWER CABLE	6FX8002-5CS01-1AF0					
M713	1	SIEMENS	SERVO MOTOR 1.10 KW, 3.5 NM, 4 AMP, 3000 RPM	1FK7044-7AF71-1FA0					
M714	1	SIEMENS	SERVO MOTOR 1.10 KW, 3.5 NM, 4 AMP, 3000 RPM	1FK7044-7AF71-1FA0					
DRV800	1	SIEMENS	INTERNAL AIR COOLING 2 X 5 DOUBLE MOTOR MODULE	6SL1310-02TE15-0AA0					
CBL807	1	SIEMENS	5 METER SIGNAL CABLE	6FX8002-2DC10-1AF0					
CBL808	2	AMP	RJ45 CAT 5 CONNECTOR	5-558530-3 (ALLIED NO. 512-5731)					
CBL808	2	AMP	RJ45 CAT 5 CONNECTOR BLACK CABLE BOOT	569875-1 (ALLIED NO. 512-5860)					
CBL809	1	SIEMENS	5 METER SIGNAL CABLE	6FX8002-2DC10-1AF0					
CBL815	1	SIEMENS	5 METER POWER CABLE	6FX8002-5DS01-1AF0					
CBL816	1	SIEMENS	5 METER POWER CABLE	6FX8002-5CS01-1AF0					
M813	1	SIEMENS	SERVO MOTOR 1.10 KW, 3.5 NM, 4 AMP, 3000 RPM, W/BRAKE	1FK7044-7AF71-1FB0					
M814	1	SIEMENS	SERVO MOTOR 1.10 KW, 3.5 NM, 4 AMP, 3000 RPM	1FK7044-7AF71-1FA0					
DRV900	1	SIEMENS	INTERNAL AIR COOLING 5 SINGLE MOTOR MODULE	6SL1310-01TE15-0AA0					
CBL909	1	SIEMENS	5 METER SIGNAL CABLE	6FX8002-2DC10-1AF0					



The Way Corporation

STOCKLIST

DATE	12/2006	SCALE	
BY	WAY COMP	PRINT	30 UP 30

JOB NO. MASTER